



# CNC Machining units CNC Bearbeitungseinheiten

	THRUST VORSCHUBKRAFT	7000 N
	WEIGHT GEWICHT	70 Kg

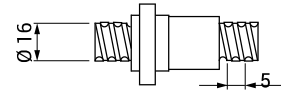

CAPACITY IN STEEL R=60  
LEISTUNG IN STAHL R=60

Ø 25 / M30

STROKE  
HUB

115 mm

TOOLHOLDER  
WERKZEUGAUFNAHME

S = ISO 30 DIN 2079  
O = HSK 50 C

SPINDLE RPM (50HZ) / SPINDELDREHZAHL

D	300	R6P	CHAIN WITH REDUCER GETRIEBEKETTE
E	400		
F	500	6P	CHAIN KETTE
G	600		
H	800	6P	
I	1000		
J	1200		
K	1500		
L	1800	4P	TIMING BELT ZAHNRIEMEN
M	2000		
N	2400		
O	3000		
P	3600	2P	
Q	4000		

**DXE 23 /115 /.. /.. /..**

MOTOR / MOTOR

205	=	90	-	1,5 kW	2P
406	=	90	-	1,5 kW	4P
606	=	90	-	1,1 kW	6P

Max frame 112 / Max Größe 112

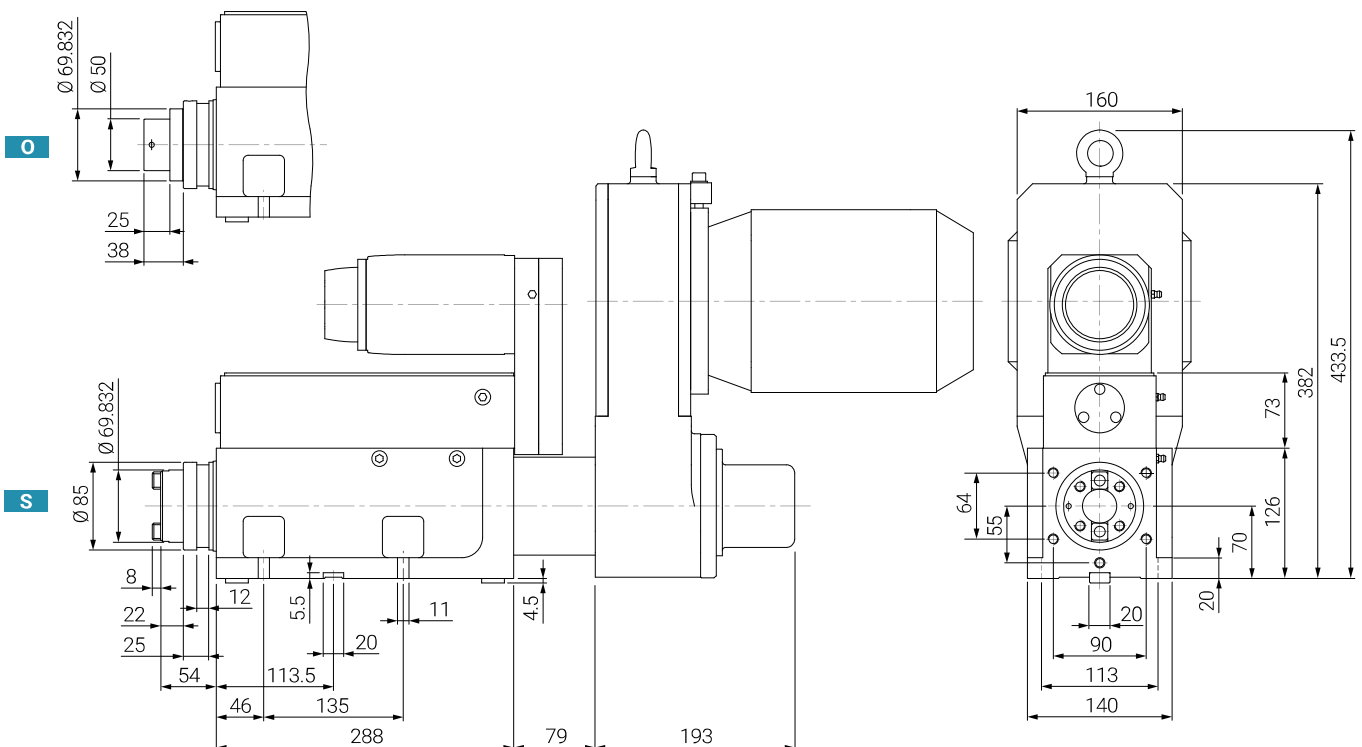

## ACCESSORIES

- Supported by a set of taper roller bearings
- Multi spindle heads
- Provision for brushless motor
- Provision for spindle motor
- Coolant through facility

## ZUBEHÖR

- Kegellager
- Mehrspindelköpfe
- Vorbereitung für Servomotor
- Vorbereitung für Spindel
- Mit Innenkühlung