



Tapping units Gewindeschneideinheiten

 LEAD SCREW
LEITPATRONE

 WEIGHT
GEWICHT

98 Kg

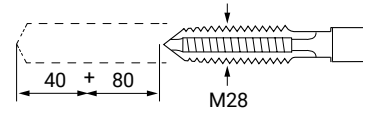

TAPPING CAPACITY IN STEEL R=60
SCHNEIDLEISTUNG IN STAHL R=60

M28

FAST STROKE
EILVORSCHUB

80 mm

TAPPING STROKE
ARBEITSVORSCHUB

40 mm

TOOLHOLDER
WERKZEUGAUFNAHME

H2 = DIN 55058 Ø 28

I = DIN 55058 Ø 36

SPINDLE RPM (50HZ) / SPINDEL DREHZAHL

A2	100	
A	160	
B	200	6P
D	300	
F	500	
G	600	4P

BELT
ZAHNRIEMEN

TX 28 /120 /.. /.. /.. /*

MOTOR / MOTOR

408 = 100 - 3,00 kW 4P

609 = 112 - 2,20 kW 6P

Max frame 112 / Max Größe 112

LEAD SCREW PITCH
STEIGUNG DER LEITPATRONE

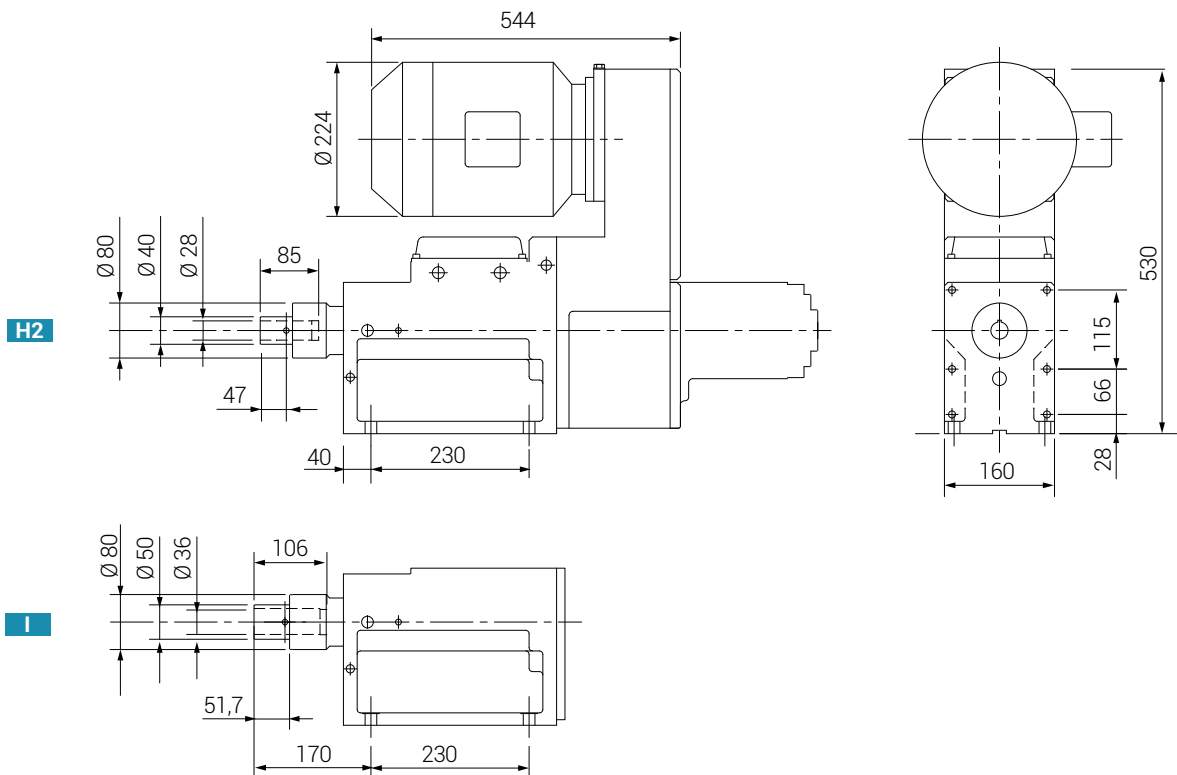

ACCESSORIES

- Multi spindle heads
- Selfbreaking motor on request

ZUBEHÖR

- Mehrspindelköpfe
- Bremsmotor auf Anfrage