

Hydraulic slide units with box ways construction Hydraulischer Vorhubschlitten

HX 38 /..

STROKE HUB mm	STRENGTH VORSCHUBKRAFT 35 bar	WEIGHT GEWICHT Kg	HYDRAULIC CYLINDER HYDRAUL ZYLINDER	RECOMMENDED FOR EMPFOHLEN FÜR
200	15500 N	92	Ø 63	DX38
300	15500 N	108	Ø 63	DX38

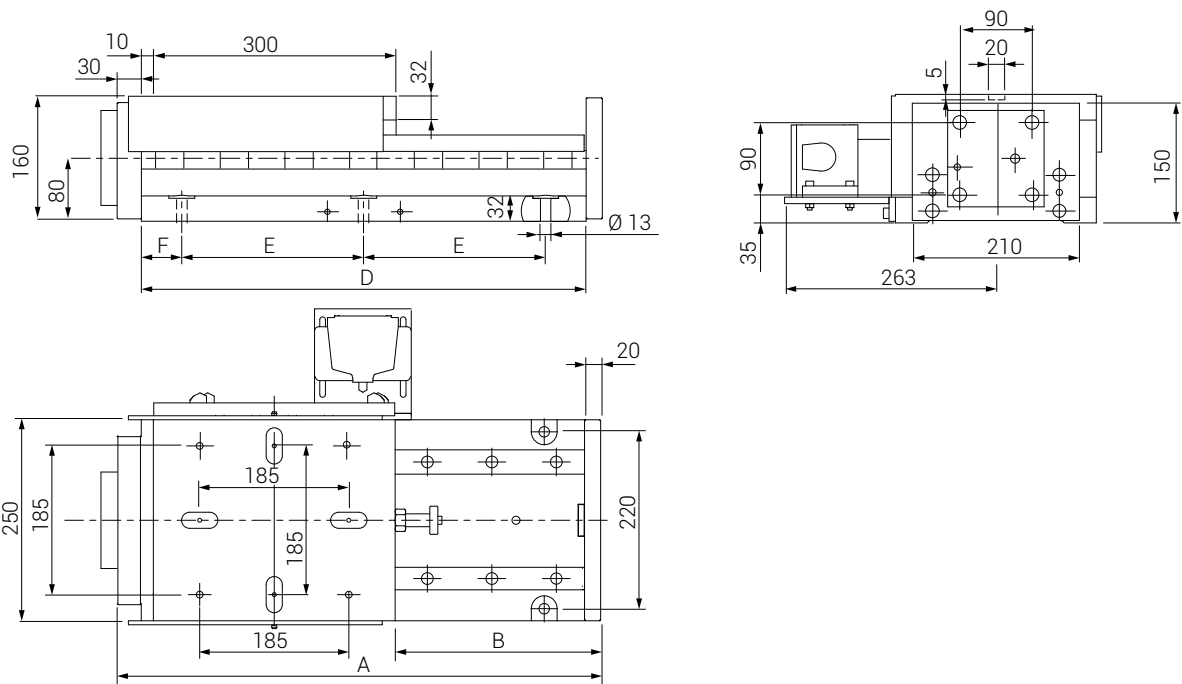

SIZE BAUGRÖßE	A	B	D	E	F
HX38.200	600	265	550	260	50
HX38.300	720	385	670	320	55

BELLOW TYPE COVER
FALTENBALGABDECKUNG

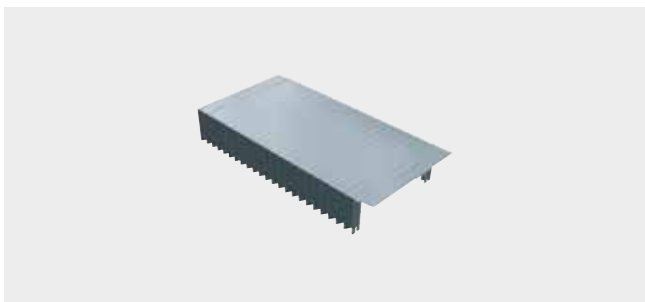

ROLLER CIRCULATING RAILS/PADS
FÜHRUNGEN MIT KUGELUMLAUFWAGEN

