

# CNC slide units with ball screw and ball bearing ways CNC Vorschubeinheiten mit Kugelumlaufspindel und linearkugellagern

**EX 28 /..**

STROKE HUB mm	STRENGHT VORSCHUBKRAFT MAX	WEIGHT GEWICHT Kg	BALL SCREW KUGELUMLAUFSPINDEL	RECOMMENDED FOR EMPFOHLEN FÜR
100	7000 N	30	Ø 20 x 5 mm	DX22 - DX28 (ISO30)
200	7000 N	34	Ø 20 x 5 mm	DX22 - DX28 (ISO30)
300	7000 N	38	Ø 20 x 5 mm	DX22 - DX28 (ISO30)

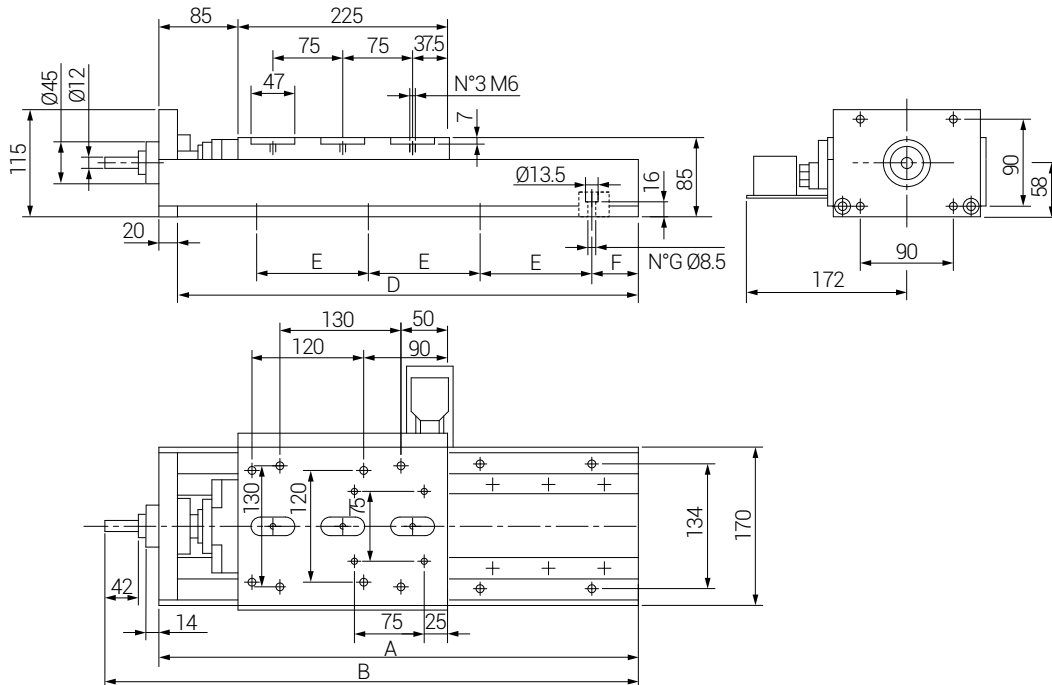

SIZE BAUGRÖÖE	A	B	D	E	F	G
EX28.100	415	482	495	120	70	6
EX28.200	515	582	495	120	50	8
EX28.300	690	757	670	120	35	10

IN LINE FEED MOTOR  
VORBEREITUNG DIREKTANTRIEB

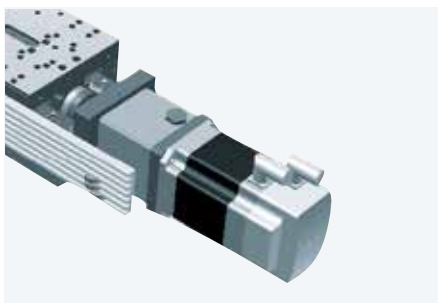

OFF SET MOTOR  
VORBEREITUNG RIEMENANTRIEB

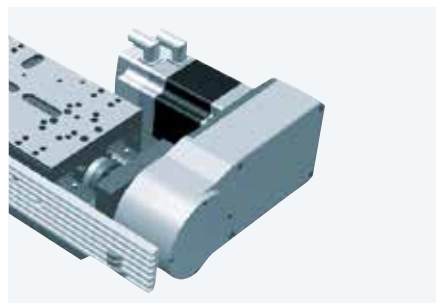

ROLLER CIRCULATING RAILS/PADS  
FÜHRUNGEN MIT KUGELUMLAUFWAGEN

