



CNC Machining units CNC Bearbeitungseinheiten

 THRUST
VORSCHUBKRAFT 9700 N

 WEIGHT
GEWICHT 140 Kg

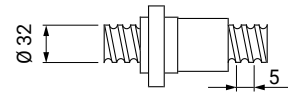

CAPACITY IN STEEL R=60
LEISTUNG IN STAHL R=60

Ø 38/ M40

STROKE
HUB

160 mm

TOOLHOLDER
WERKZEUGAUFNAHME

T= ISO 40

SPINDLE RPM (50HZ) / SPINDELDREHZAHL

A	160		
B	200	R6P	
C	250		CHAIN WITH REDUCER GETRIEBEBETTE
D	300		
E	400	R4P	
F	500		
G	600		
H	800	6P	
I	1000		
J	1200		
K	1500	4P	TIMING BELT ZAHNRIEMEN
L	1800		
M	2000		
N	2400		
O	3000	2P	
P	3600		
Q	4000		

DXE 42 /160 /.. /.. /..

MOTOR / MOTOR

207	=	100	-	3,00 kW	2P
407	=	100	-	2,2 kW	4P
609	=	112	-	2,2 kW	6P

Max frame 112 / Max Größe 112

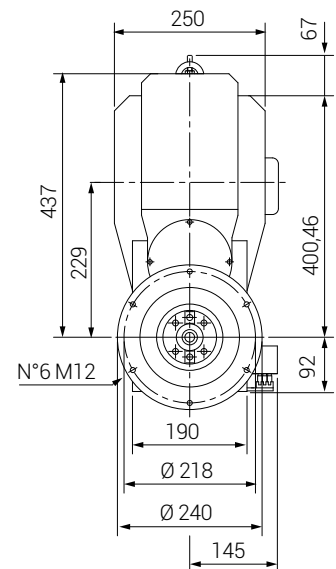
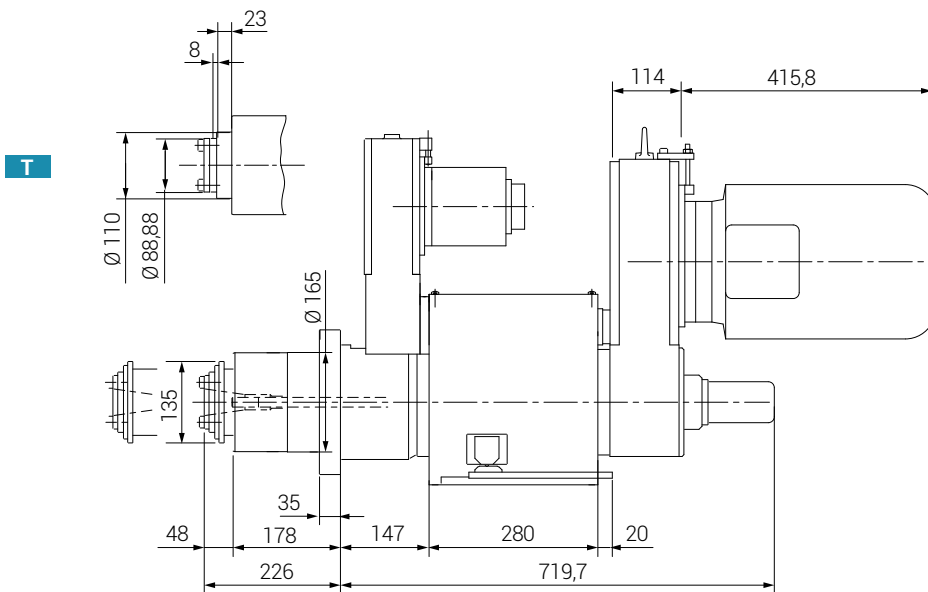

ACCESSORIES

- Multi spindle heads
- Provision for brushless motor
- Provision for spindle motor

ZUBEHÖR

- Mehrspindelköpfe
- Vorbereitung für Servomotor
- Vorbereitung für Spindel