



Units for combined drill-tapping Bohr- und Gewindeschneideinheiten

	THRUST VORSCHUBKRAFT	1350 N
	WEIGHT GEWICHT	16-21 Kg

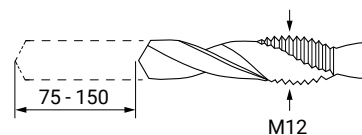

TAPPING CAPACITY IN STEEL R=60
SCHNEIDLEISTUNG IN STAHL R=60

M12

STROKE
HUB

75 mm
150 mm

TOOLHOLDER
WERKZEUGAUFNAHME

A = B12 DIN 238
LC = ER20
Compensated / Spannzangenhalter

SPINDLE RPM (50HZ) / SPINDEL DREHZAHL

Z1 750 4/6 P
1200

Z2 1200 2/4P TIMING BELT
2400 ZAHNRIEMEN

Z3 2000 2/4P
4000

DTX 12 /.. /.. /.. /.. /..

MOTOR / MOTOR

901 = 80 - 0.8/0.6 kW 2/4 P
902 = 80 - 0.55/0.45 kW 4/6 P

Max frame 80 / Max Größe 80

HYDROCHECK / HYDRAULIKBREMSE

HF50 = STROKE/ HUB 50 mm
HF75 = STROKE/ HUB 75 mm
HF100 = STROKE/ HUB 100 mm

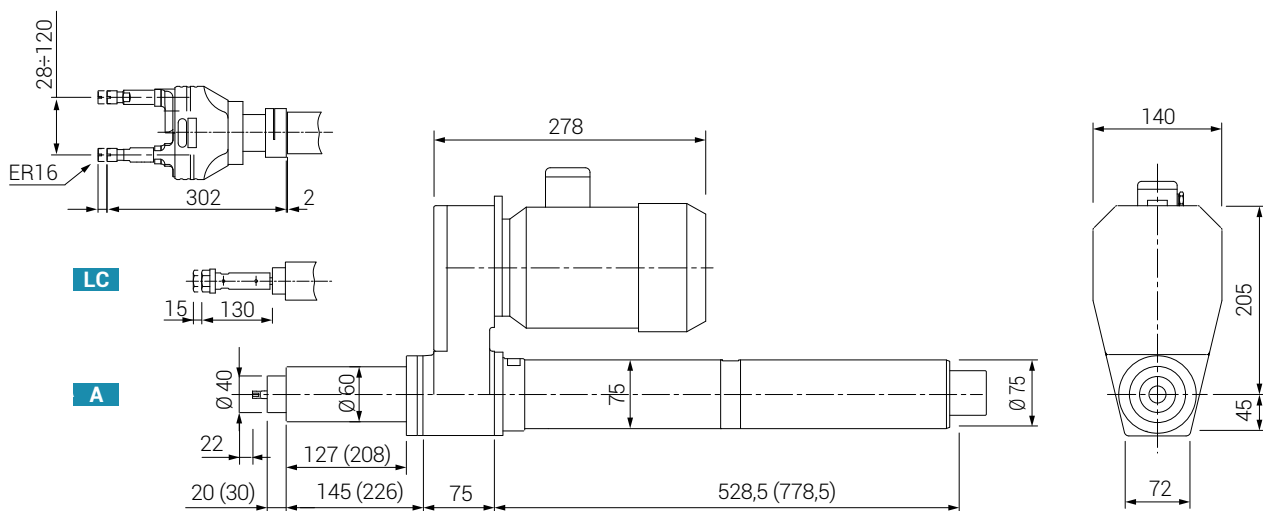

Dimension () are for the 150 mm stroke unit / (Quoten) = Einheit mit Hub 150

ACCESSORIES

(Page 40)

- Multi spindle heads with compensating spindle
- Selfbreaking motor on request
- Double polarity motor
- For brackets see 3D pictures

ZUBEHÖR

(Seite 40)

- Mehrspindelköpfe mit Kompensierte Spindel
- Bremsmotor auf Anfrage
- Polumschaltbarer Motor
- Zubehör siehe 3D Abbildung

